

Versatile: lorry double deck loading or pallet truck/stacker operation

3-phase AC motor for maximum performance and low energy consumption

ShockProtect to protect the driver, truck and load

Electric tiller for easy steering

Excellent handling utilising ProTraLink's heavy duty torsion bar technology

Fixed operator platform (optional)



ERD 220

Electric pedestrian pallet truck/stacker (2000 kg)

The ERD 220 electric pedestrian controlled truck is extremely versatile when it comes to load handling. A specialist in lorry double deck loading, it is equally at home when transporting loads efficiently over long distances or stacking/retrieving loads up to 2560 mm high.

The design of the truck is very robust: An 8 mm steel chassis and box forks made of sectional steel allow for heavy-duty applications with heavy loads.

The ERD 220 is also ideally suited to both pedestrian and rider operation. In rider mode the ERD reaches impressive speeds of up to 12.5 km/h. This means that goods can be

handled and transported particularly efficiently.

It also features maximum operator safety and travel comfort:

- In addition to the soft suspension of the operator platform, the entire drive system is cushioned with "ShockProtect" suspension. The advantage: Less strain on the driver's spine column. Considerably less impact on the chassis and all components of the ERD 220.
- Electric steering for fatigue-free travel, even with heavy loads.
- The maximum speed of the truck is automatically reduced around bends, in relation to the steering angle.

- A fixed operator platform (optional) ensures outstanding driver protection through extra high sides.

Up to 465 Ah high performance batteries are available for the heavy-duty applications. Combined with state-of-the-art 3-phase AC systems, this ensures longer uptimes with the same low level of energy consumption. For multi-shift operation the ERD 220 comes with a sideways battery removal option. For less demanding applications the ERD 220 entry model is available.

ERD 220

ERD 220 with folding platform

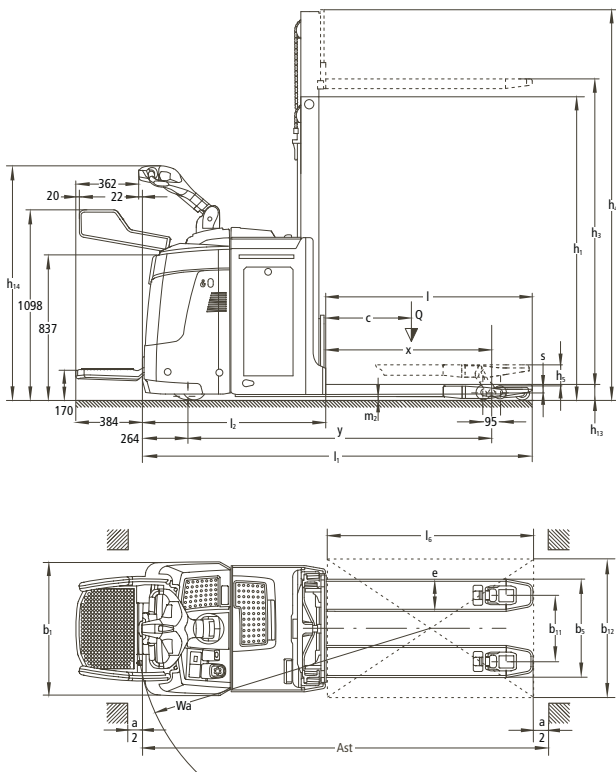

ERD 220 with fixed platform

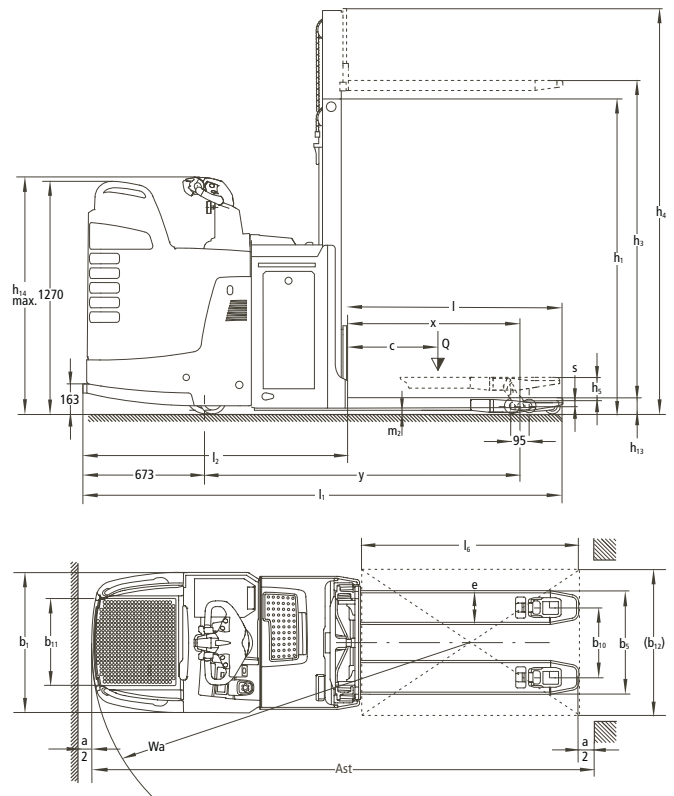

Mast table (mm) ERD 220				
Designation	h_1	h_2	h_3	$h_4^{1)}$
ZT	1350	100	1660	2150
	1530	100	2010	2500
	1810	100	2560	3050
DT	1366	100	2500	2990
ERD 220 entry				
Designation	h_1	h_2	h_3	$h_4^{1)}$
ZT	1350	100	1660	2150
	1530	100	2010	2500

1) initial lift + 122 mm



Technical data in line with VDI 2198 as at: 05/2010

Identification	1.1	Manufacturer (abbreviation)	Jungheinrich	Jungheinrich	Jungheinrich	1.1	
	1.2	Manufacturer's type designation	ERD 220	ERD 220	ERD 220	1.2	
			entry	folding platform	fixed platform		
	1.3	Drive	electric	electric	electric	1.3	
	1.4	Operator type	stand/pedestrian	stand/pedestrian	stand	1.4	
	1.5	Load capacity/rated load	Q (t)	2	2	1.5	
		Load capacity mast lift	Q (t)	1	1		
		Load capacity support arm lift	Q (t)	2	2		
	1.6	Load centre distance	c (mm)	600	600	600	1.6
1.8	Load distance (Centre of load axle to fork face)	x (mm)	957 ¹⁾	957 ¹⁾	957 ¹⁾	1.8	
1.9	Wheelbase	y (mm)	1677 ¹⁾	1677 ¹⁾	1677 ¹⁾	1.9	
Weights	2.1	Service weight incl. battery (see line 6.5)	kg	1186	1110	1168	2.1
	2.2	Axle loading, laden front/rear	kg	1958/1228	1920/1190	1920/1248	2.2
	2.3	Axle loading, unladen front/rear	kg	348/838	310/800	310/858	2.3
Wheels, Chassis	3.1	Tyres	Vulkollan®	Vulkollan®	Vulkollan®	3.1	
	3.2	Tyre size, front	mm	230 x 77	230 x 77	230 x 77	3.2
	3.3	Tyre size, rear	mm	85 x 95/85 x 75	85 x 95/85 x 75	85 x 95/85 x 75	3.3
	3.4	Additional wheels (dimensions)	mm	140 x 50	140 x 50	140 x 50	3.4
	3.5	Wheels, number front rear (x = driven wheels)		1x +2/2 or 4	1x +2/2 or 4	1x +2/2 or 4	3.5
	3.6	Track width, front	b ₁₀ (mm)	512	512	512	3.6
	3.7	Track width, rear	b ₁₁ (mm)	385	385	385	3.7
Basic Dimensions	4.2	Closed mast height	h ₁ (mm)	1350	1350	1350	4.2
	4.4	Lift (standard mast)	h ₃ (mm)	1660	1660	1660	4.4
	4.5	Height, mast extended	h ₄ (mm)	2150	2150	2150	4.5
	4.6	Initial lift	h ₅ (mm)	122	122	122	4.6
	4.9	Height of tiller in drive position min./max.	h ₁₄ (mm)	1158/1414	1158/1414	1090/1160	4.9
	4.15	Height, lowered	h ₁₃ (mm)	90	90	90	4.15
	4.19	Overall length (without load)	l ₁ (mm)	2246	2174 ²⁾	2584 ²⁾	4.19
	4.20	Length to face of forks	l ₂ (mm)	1056	984 ²⁾	1394 ²⁾	4.20
	4.21	Overall width	b ₁ /b ₂ (mm)	770/-	770/-	770/-	4.21
	4.22	Fork dimensions	s/e/l (mm)	56/185/1190	56/185/1190	56/185/1190	4.22
	4.25	Width across forks	b ₅ (mm)	570	570	570	4.25
	4.32	Ground clearance, centre of wheelbase	m ₂ (mm)	20	20	20	4.32
4.33	Aisle width for pallets 1000 x 1200 crossways	Ast (mm)	2465 ⁵⁾	2393 ⁵⁾	2841 ⁵⁾	4.33	
4.34	Aisle width for pallets 800 x 1200 lengthways	Ast (mm)	2465 ⁵⁾	2393 ⁵⁾	2841 ⁵⁾	4.34	
4.35	Turning radius	Wa (mm)	2022 ¹⁾	1950 ¹⁾	2398 ¹⁾	4.35	
Performance Data	5.1	Travel speed, laden/unladen	km/h	7.2/8.2	9.5/12.5	9.5/12.5	5.1
	5.2	Lift speed, laden/unladen	m/s	0.13/0.22	0.14/0.24	0.14/0.24	5.2
	5.3	Lowering speed, laden/unladen	m/s	0.21/0.15	0.27/0.25	0.27/0.25	5.3
	5.7	Gradeability, laden/unladen	%	8/15	8/16	8/16	5.7
	5.8	Max. gradeability, laden/unladen	%	8/15	8/16	8/16	5.8
	5.10	Service brake		electric	electric	electric	5.10
E-Motor	6.1	Drive motor rating S ₂ , 60 min	kW	2.8	2.8	2.8	6.1
	6.2	Lift motor rating at S ₃ , 15 %	kW	2	2	2	6.2
	6.3	Battery acc. to DIN 43531/35/36 A, B, C, no		43535, B	43535, B	43535, B	6.3
	6.4	Battery voltage, nominal capacity K _s	V/Ah	24/375	24/250 ³⁾	24/250 ³⁾	6.4
	6.5	Battery weight	kg	288	220 ⁴⁾	220 ⁴⁾	6.5
	6.6	Energy consumption acc. to VDI cycle	kWh/h	0.67	0.67	0.67	6.6
Others	8.1	Type of drive control		AC SpeedControl	AC SpeedControl	AC SpeedControl	8.1
	8.4	Sound level at the driver's ear according to EN 12053	dB(A)	67	67	67	8.4

- 1) load section lowered +48 mm
2) battery compartment L/L high +72 mm
3) battery compartment L = 375 Ah, L high = 465 Ah
4) 375 Ah = 288 kg, 465 Ah = 368 kg
5) diagonal in accordance with VDI +255 mm

Make use of the advantages

Travel dynamically and efficiently

Advanced 3-phase drive technology and control electronics (SpeedControl) ensure reliable and economical handling which can be tailored to the requirements of any application:

- Powerful 2.8 kW drive motor with state-of-the-art 3-phase AC control system.
- A choice of travel parameters suitable for every application (optional).
- Two years warranty on the drive motor.

Outstanding travel and lift performance

- Jungheinrich ShockProtect: Protection for the driver, truck and load through additional drive suspension. The suspension cushions the operator and chassis against severe impacts.
- Sprung and damped support wheels – linked via the ProTraLink's heavy duty torsion bar technology – ensure safe handling under all driving conditions.
- Controlled hydraulics (optional) for gentle load discharge and lowering and for precise pallet positioning in the racking.

Work flexibly and safely

- Rider or pedestrian mode, depending on the application, by folding the platform in or out. The travel speed is automatically reduced in pedestrian mode.
- A fixed platform with an enclosed operator position is available (option) if required.
- In double deck mode two pallets each containing 1000 kg can be transported on top of each other at a maximum speed of 7 km/h (ERD 220 entry model: 5 km/h).



Fixed operator platform for maximum driver safety

Fully informed at all times

Comprehensive control instrumentation gives the operator the reassurance of full information at all times:

- "CanDis" information display (optional) with additional service hour display and service code storage.
- PIN activation of truck and automatic time-out with "CanCode" (optional).

Outstanding ergonomics

The new, tiller arm, protected against water ingress has rocker switches on both sides and a clear red/green colour code to match the ergonomic requirements of the operator. The ERD 220 also offers the following features:

- Fatigue-free electric steering.
- Height-adjustable tiller arm for fixed platform (optional).
- Additional pallet stop on chassis ensures precise positioning of two pallets stacked on top of each other.
- Detachable storage tray on battery lid.

Long uptimes

Large battery capacities ensure long uptimes.

- Battery compartment M: 3 PzS 250 Ah.
- Battery compartment L: 3 PzS 375 Ah.
- Battery compartment L high: 3PzS 465 Ah.
- Side battery removal option for multi-shift environments.
- On-board charger (24 V/30 A for wet cell batteries and maintenance-free batteries) for easy charging at any mains socket (optional).

Optional equipment

- Load backrest.
- Lowering speed reduction for pallet lowering.
- Cold store version.
- Entry skids for lifting perimeter based pallets.
- High-performance lift.
- Slow travel with lowered forks (fork wear reduction).
- ERD 220 entry model with reduced performance levels.



Precise operation with the pallet stop

Jungheinrich UK Ltd.

Head Office:

Sherbourne House · Sherbourne Drive
Tilbrook · Milton Keynes MK7 8HX
Phone 01908 363100
Fax 01908 363180

info@jungheinrich.co.uk
www.jungheinrich.co.uk



JUNGHEINRICH
Well worthwhile