

Powerful and economical through maintenance-free 3-phase AC drive motor

Manoeuvrable and compact through very short front length

Extremely space-saving and safe with tiller in upright position through crawl speed button

Sensitive lifting and lowering from the tiller through adjustable speed range of hydraulic motor

Integrated charger for easy charging at any mains socket



EJC 110/112

Electric pedestrian stacker (1000 and 1200 kg)

The pedestrian stackers of the EJC range 1 show their strength wherever transporting over short distances and stacking up to a lift height of 3600 mm take place. With a very short front length (L_2 dimension) of only 637 mm, the EJC is particularly effortless and safe to manoeuvre, even in confined spaces.

The high performance drive motor in 24 V 3-phase AC technology is an added bonus.

Its optimised efficiency factor ensures high speed and excellent acceleration in every situation – the best preconditions for fast, efficient goods throughput.

Another advantage: the lift control. This enables the operator to pick up loads accurately and sensitively. This makes particularly the depositing of large loads in narrow racking easier. The remarkably low noise development during slow lifting

also makes work for the operator easier. Proportional hydraulics ensure gentle depositing of the load on the floor or in the racking.

The required power is supplied to the EJC 110/112 via batteries with capacities up to 200 Ah. An integrated charger facilitates comfortable and reliable charging of the installed battery at any 230V mains socket.

EJC 110/112

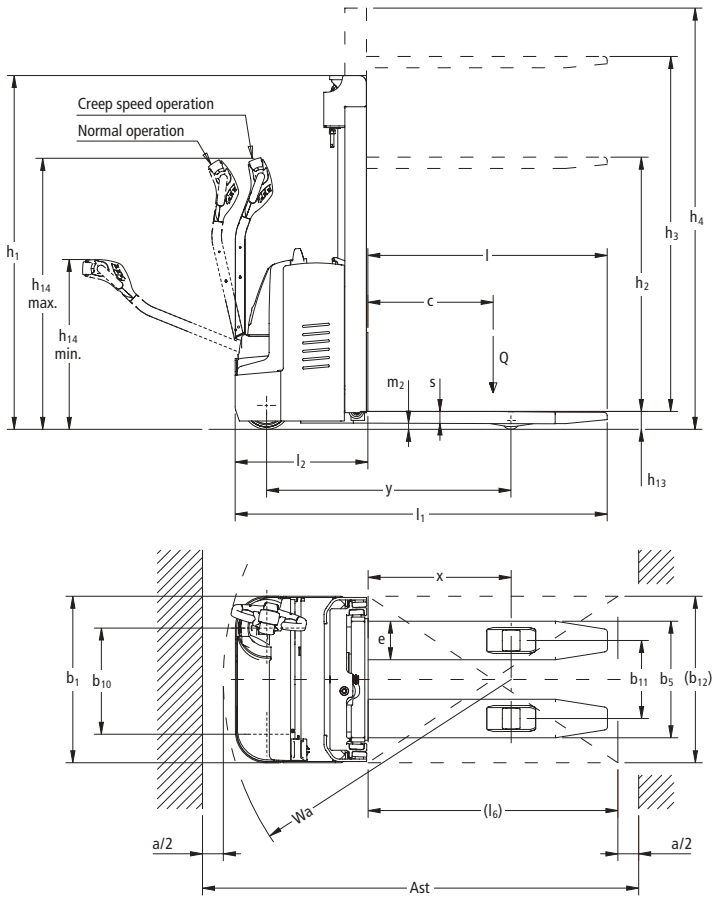

Standard mast types (mm)								
Designation	Closed mast height h_1^*	Lift height h_3	Free lift h_2	Extended mast height h_4	Closed mast height h_1^*	Lift height h_3	Free lift h_2	Extended mast height h_4
	EJC 110				EJC 112			
Two-stage mast ZT	1750	2500	100	2973	1750	2500	100	2973
	1850	2700	100	3173	1850	2700	100	3173
	1950	2900	100	3373	1950	2900	100	3373
	2100	3200	100	3673	2100	3200	100	3673
	2300	3600	100	4073	2300	3600	100	4073
Two-stage mast ZZ					1700	2500	1227	2973
					1900	2900	1427	3373
					2050	3200	1577	3673
					2250	3600	1777	4073

* at 100 mm free lift

Technical Data in line with VDI 2198 as at: 09/2005

Identification	1.1	Manufacturer (abbreviation)		Jungheinrich	Jungheinrich	1.1
	1.2	Manufacturer's type designation		EJC 110	EJC 112	1.2
	1.3	Drive (electric – battery or mains, diesel, petrol, fuel gas, manual)		electric (battery)	electric (battery)	1.3
	1.4	Type of operation (hand, pedestrian, standing, seated, order picker)		pedestrian	pedestrian	1.4
	1.5	Load capacity/rated load	Q (t)	1.0	1.2	1.5
	1.6	Load centre distance	c (mm)	600	600	1.6
	1.8	Load distance, centre of drive axle to fork	x (mm)	687	687	1.8
	1.9	Wheelbase	y (mm)	1171	1171	1.9
	Weights	2.1	Service weight incl. battery (see line 6.5)	kg	805 ¹⁾	820 ¹⁾
2.2		Axle loading, laden front/rear	kg	650/1155 ¹⁾	660/1360 ¹⁾	2.2
2.3		Axle loading, unladen front/rear	kg	565/240 ¹⁾	575/245 ¹⁾	2.3
Wheels, Chassis	3.1	Tyres (solid rubber, superelastic, pneumatic, polyurethane)		PU/Vulk	PU/Vulk	3.1
	3.2	Tyre size, front		230 x 70	230 x 70	3.2
	3.3	Tyre size, rear		85 x 100	85 x 100	3.3
	3.4	Additional wheels (dimensions)		140 x 54	140 x 54	3.4
	3.5	Wheels, number front/rear (x = driven wheels)		1x + 1/2	1x + 1/2	3.5
	3.6	Track width, front	b ₁₀ (mm)	510	510	3.6
	3.7	Track width, rear	b ₁₁ (mm)	375	375	3.7
Basic Dimensions	4.2	Lowered mast height	h ₁ (mm)	1950 ¹⁾	1950 ¹⁾	4.2
	4.3	Free lift	h ₂ (mm)	100 ¹⁾	100 ¹⁾	4.3
	4.4	Lift height	h ₃ (mm)	2900 ¹⁾	2900 ¹⁾	4.4
	4.5	Extended mast height	h ₄ (mm)	3373 ¹⁾	3373 ¹⁾	4.5
	4.9	Height of tiller in drive position min./max.	h ₁₄ (mm)	820/1310	820/1310	4.9
	4.15	Lowered height	h ₁₃ (mm)	90	90	4.15
	4.19	Overall length	l ₁ (mm)	1787	1787	4.19
	4.20	Length to face of forks	l ₂ (mm)	637	637	4.20
	4.21	Overall width	b ₁ /b ₂ (mm)	800	800	4.21
	4.22	Fork dimensions	s/e/l (mm)	56/185/1150	56/185/1150	4.22
	4.25	Width over forks	b ₅ (mm)	560	560	4.25
	4.32	Ground clearance, centre of wheelbase	m ₂ (mm)	30	30	4.32
	4.33	Aisle width for pallets 1000 x 1200 crossways	Ast (mm)	2046 ³⁾	2046 ³⁾	4.33
	4.34	Aisle width for pallets 800 x 1200 lengthways	Ast (mm)	2096 ⁴⁾	2096 ⁴⁾	4.34
	4.35	Turning radius	Wa (mm)	1383 ²⁾	1383 ²⁾	4.35
Performance Data	5.1	Travel speed, laden/unladen	km/h	6.0/6.0	6.0/6.0	5.1
	5.2	Lift speed, laden/unladen	m/s	0.13/0.20	0.12/0.20	5.2
	5.3	Lowering speed, laden/unladen	m/s	0.43/0.40	0.43/0.40	5.3
	5.8	Max. gradient performance, laden/unladen	%	8/16	8/16	5.8
	5.10	Service brake		electric	electric	5.10
E-Motor	6.1	Drive motor rating S ₂ 60 min.	kW	1.0	1.0	6.1
	6.2	Lift motor rating at S ₃ 10 %	kW	1.7	1.9	6.2
	6.3	Battery acc. to DIN 43531/35/36 A, B, C, no		no	no	6.3
	6.4	Battery voltage, nominal capacity K ₅	V/Ah	24/200	24/200	6.4
	6.5	Battery weight	kg	185	185	6.5
Others	8.4	Sound level at the driver's ear according to DIN 12 053	dB(A)	70	70	8.4
1) Values for standard mast 2-stage telescopic 2) Tiller in upright position (crawl speed) 3) Diagonal according to VDI + 214 mm 4) Diagonal according to VDI + 138 mm						

This specification sheet according to VDI regulation 2198 only provides technical values for the standard truck. Non-standard tyres, different masts, additional equipment, etc. could produce other values. Right reserved for technical changes and improvements.

Make use of the advantages

Innovative 3-phase AC technology

Jungheinrich motors in 3-phase AC technology provide you with more performance efficiency and a reduction in operating costs at the same time. Make use of these advantages:

- High efficiency factor with excellent energy management.
- Powerful acceleration.
- Quick travel direction change without the usual "pause for thought".
- No carbon brushes – the drive motor is maintenance-free.
- Two-year warranty on drive motor.



The EJC cuts a fine figure even in narrow racking aisles

Manoeuvrable and compact

Due to its very short front length of only 637 mm, the EJC can be operated even in the most confined spaces. If even this is not sufficient, work can carry on with the tiller in the upright position at crawl speed.

Comfortable depositing and retrieval

All lifting and lowering functions are effortlessly controlled from the multi-

function tiller head. The operator can thus totally concentrate on depositing or retrieval. Other performance characteristics are included that make depositing and retrieval operations remarkably safe and economically efficient:

- Precise and gentle depositing of loads through Jungheinrich speed-controlled hydraulic motor.
- Low noise development during slow lifting through lift control.
- Gentle depositing of load through proportional hydraulics.
- Long safety tiller for adequate distance between operator and truck.

Informed at any time

Extensive control instruments and adjustment possibilities facilitate control at a glance:

- Battery discharge indicator (3-colour light emitting diode) with lift stop.
- Information display "CanDis" (optional) with added operating hour display and fault code memory.
- Activation of truck via PIN and selection of 3 travel programs through "CanCode" (optional).
- Adjustable travel parameters through CanDis and CanCode (optional).



Access authorisation CanCode and CanDis (optional)

Comfortable travel

The Jungheinrich impulse control "Speed-Control" facilitates comfortable, safe travel with adjustment possibilities to any application:

- The pre-set speed on the travel switch is maintained in every travel situation.
- The operator is able to choose between 3 different travel programs (optional).
- Regenerative braking on reducing the travel speed.
- Very low noise level during travel.



Integrated charger 30 A for comfortable battery charging at any mains socket

Long operating times

- Energy-saving 3-phase AC technology – in combination with battery capacities up to 200 Ah (2 EPzB 130/150/200 Ah) – ensures long operating times.
- Integrated charger (24V/30A) for wet and maintenance-free batteries for easy charging at any mains socket.

Additional equipment

- Battery discharge indicator/operating hour meter.
- Access authorisation via CanCode.
- Vertical load guard.

Jungheinrich UK Ltd.

Head Office:

Sherbourne House
Sherbourne Drive
Tilbrook
Milton Keynes MK7 8HX
Telephone 01908 363100

info@jungheinrich.co.uk
www.jungheinrich.co.uk

ISO 9001, ISO 14001
Certification of Quality and
Environment Management.



Jungheinrich trucks
conform to the European
Safety Requirements.



JUNGHEINRICH
Well worthwhile