

Universal truck with flexible application potential

Precise load positioning through sensitive lowering via the tiller

Fully manoeuvrable with tiller in upright position through crawl speed button

Optimum travel characteristics through load-dependent, effective support wheel system



EJD 220

Electric pedestrian pallet truck/stacker (2000 kg)

The EJD 220 combines the performance characteristics of a pedestrian pallet truck and stacker in one vehicle: from lorry loading and offloading to pallet transporting, to stacking tasks (max. 2560 mm lift height), it makes an impact as a flexibly applicable universal truck.

Its greatest advantage: as a double-deck stacker, it is able to pick up two Euro pallets at the same time. Compared with a traditional pallet truck/stacker, it can thus get through its workload twice as fast. The EJD can carry 2000 kg when applied

as a pallet truck, 1000 kg with the forks raised or 2 x 1000 kg in double-deck operation.

The 5-wheel system consisting of central drive wheel, 2 laterally stabilising support wheels and 2 load wheels ensures the required stability and safe travel – an absolute must on ramps and loading platforms.

The raising support arms also contribute to safe travel, for instance on thresholds, ramp kinks and uneven floors. They

increase the floor clearance and thus ensure simple and safe “cross-over”.

And if space becomes too tight on lorries or in narrow aisles, the crawl speed button facilitates safe travel with the tiller in the upright position. One touch of the button is sufficient: the brake is released and the drive switch controls travel speed at automatically much reduced speed.

**JUNGHEINRICH**

EJD 220

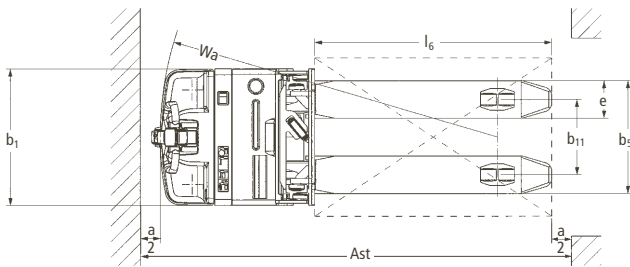
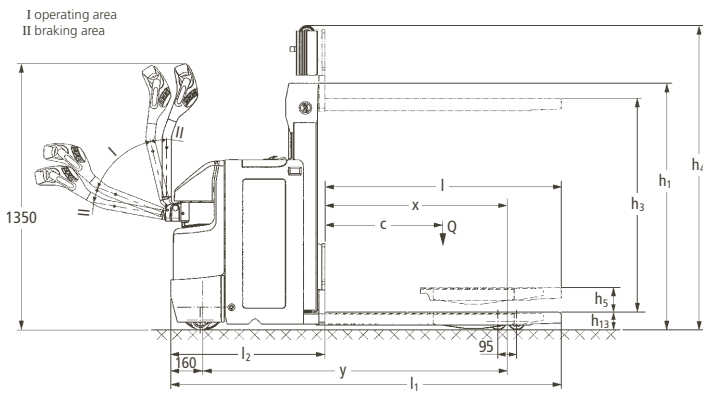

Standard mast types (mm)		
Two-stage masts ZT		
h_1	h_3	h_4
1250	1660	2106
1430	2010	2456
1700	2560	3006
Three-stage masts DT		
h_1	h_3	h_4
1110	2050	2500
1210	2350	2800



Technical Data in line with VDI 2198 as at: 09/2005

Identification	1.1	Manufacturer (abbreviation)		Jungheinrich	1.1
	1.2	Manufacturer's type designation		EJD 220	1.2
	1.3	Drive (electric, diesel, petrol, fuel gas, mains electric, manual)		electric	1.3
	1.4	Type of operation (hand, pedestrian, standing, seated, order picker)		manual	1.4
	1.5	Load capacity/rated load	Q (t)	2.0	1.5
	1.6	Load centre distance	c (mm)	600	1.6
	1.8	Load distance, centre of drive axle to fork	x (mm)	925 ³⁾	1.8
	1.9	Wheelbase	y (mm)	1550 ³⁾	1.9
	Weights	2.1	Service weight incl. battery (see line 6.5)	kg	960
2.2		Axle loading, laden front/rear	kg	1130/1830	2.2
2.3		Axle loading, unladen front/rear	kg	710/250	2.3
Wheels, Chassis	3.1	Tyres (solid rubber, superelastic, pneumatic, polyurethane)		PU	3.1
	3.2	Tyre size, front		230x65	3.2
	3.3	Tyre size, rear		85x75	3.3
	3.4	Additional wheels (dimensions)		100	3.4
	3.5	Wheels, number front/rear (x = driven wheels)		1x/4	3.5
	3.7	Track width, rear	b ₁₁ (mm)	380	3.7
	Basic Dimensions	4.2	Lowered mast height	h ₁ (mm)	1250
4.4		Lift height	h ₃ (mm)	1660	4.4
4.5		Extended mast height	h ₄ (mm)	2106	4.5
4.6		Initial lift	h ₅ (mm)	125	4.6
4.9		Height of tiller in drive position min./max.	h ₁₄ (mm)	850/1350	4.9
4.15		Lowered height	h ₁₃ (mm)	90	4.15
4.19		Overall length	l ₁ (mm)	1975	4.19
4.20		Length to face of forks	l ₂ (mm)	785	4.20
4.21		Overall width	b ₁ /b ₂ (mm)	690	4.21
4.22		Fork dimensions	s/e/l (mm)	65/190/1190	4.22
4.25		Width over forks	b ₅ (mm)	570	4.25
4.32		Ground clearance, centre of wheelbase	m ₂ (mm)	30	4.32
4.33		Aisle width for pallets 1000x1200 crossways	Ast (mm)	2515 ¹⁾	4.33
4.34		Aisle width for pallets 800x1200 lengthways	Ast (mm)	2395 ²⁾	4.34
4.35		Turning radius	Wa (mm)	1710 ³⁾	4.35
Performance Data	5.1	Travel speed, laden/unladen	km/h	6.0/6.0	5.1
	5.2	Lift speed, laden/unladen	m/s	0.14/0.24	5.2
	5.3	Lowering speed, laden/unladen	m/s	0.47/0.24	5.3
	5.8	Max. gradient performance, laden/unladen	%	9/15	5.8
	5.10	Service brake		electromagnetic	5.10
E-Motor	6.1	Drive motor rating S ₂ 60 min.	kW	1.5	6.1
	6.2	Lift motor rating at S ₃ 10 %	kW	1.5	6.2
	6.3	Battery acc. to DIN 43531/35/36 A, B, C, no		43535 B	6.3
	6.4	Battery voltage, nominal capacity K _s	V/Ah	24/230	6.4
	6.5	Battery weight	kg	220	6.5
Others	8.1	Type of drive control		impulse	8.1

- 1) diagonal according to VDI: + 340 mm
 2) diagonal according to VDI: + 210 mm
 3) load section lowered: + 75 mm

Make use of the advantages



Superior in every travel situation

Powerful drive motor and "intelligent" controls

Advanced drive technology and control electronics (SpeedControl) ensure safe travel with adjustment options for every application:

- The set speed on the drive switch is maintained in every travel situation – even on gradients.
- The EJD 220 is automatically braked during unintentional rolling on ramps.
- Individually adjustable travel parameters facilitate optimum adjustment to every application.
- Energy reclamation through regenerative braking by slowing down the travel speed.
- 2-year warranty on drive motor.

Robust construction even for the most intensive applications

- Chassis made of high-grade 8 mm steel.
- Torsion-resistant support arms with drawbar kinematics – no sagging on thresholds, above all with heavy loads.

Comfortable stacking and retrieval

All lifting and lowering functions are effortlessly controlled from the tiller head. This eliminates an awkward reaching round to levers on the truck chassis – compared with traditional trucks. Jungheinrich proportional hydraulics ensure here the sensitive control of the lowering speed – a great advantage, for example, for precise and soft depositing of loads on racking shelves.



Comfortable during stacking and retrieval

Always as much support as required

The more weight on the forks or support arms, the more supporting force is required. In order for the EJD to travel safely in every situation, even with a 2000 kg load, its hydraulic support wheel system operates load-dependent: the supporting force is increased or decreased dependent on the load.

Optimum cornering

The sprung, hydraulically cushioned support wheels are hydraulically linked. This system actively distributes the stabilising



Stable also during cornering

force dependent on travel conditions: evenly over all wheels during straight travel; concentrated on the outer support wheel during cornering.

Extended operating times

Battery capacities up to 250 Ah ensure long operating times.

- 2 PzS 180/230/(250)Ah battery.
- Integrated charger (24V/30A for wet and maintenance-free batteries) for effortless recharging at any mains socket (optional).

Reduced maintenance

- Easy access to all aggregates through one-piece front cover.
- The drive wheel can be removed quickly and easily through a drill hole in the chassis apron.

Additional equipment

- Load section for sideways battery removal.
- Cold store version.
- Vertical load guard.
- Battery discharge indicator/operating hour meter.

Jungheinrich UK Ltd.

Head Office:

Sherbourne House · Sherbourne Drive
Tilbrook · Milton Keynes MK7 8HX
Phone 01908 363100
Fax 01908 363180

info@jungheinrich.co.uk
www.jungheinrich.co.uk

Jungheinrich AG
ISO 9001, ISO 14001
Certification of Quality and
Environment Management.



Jungheinrich trucks
conform to the European
Safety Requirements.



JUNGHEINRICH
Well worthwhile