

**Stand-on platform
for flexible operation**

**ProTrac for traction and
stability in all situations**

**Sensitive lifting/lowering
through Proportional Hydraulics**

**Electric tiller steering (optional)
for effortless steering**



ERC 212/214/216

Electric pedestrian operated stacker (1200/1400/1600 kg)

The Jungheinrich ERC 212/214/216 is a combination of manoeuvrable pedestrian stacker and fast, comfortable stand-on truck.

As a pedestrian stacker, the ERC provides:

- Excellent visibility through the slender mast,
- Comfortable operation of lifting/lowering function from the tiller head,
- Depositing in racking locations up to 5350 mm (ERC 214),
- Safe 4-point wheel traction during stacking and retrieval through hydraulic locking of support wheels,
- Sensitive lifting and lowering speed control through Jungheinrich Proportional Hy-

draulics – e.g. for precise and gentle depositing of the load in the racking.

And if space becomes tight during stacking or, for example, during load pick-up in lorries, the operator stand-on platform and side guards are simply folded away and the ERC is transformed back into a space-saving pedestrian truck. The low height of the stand-on platform ensures effortless and fast mounting and dismounting.

As a stand-on truck, the ERC provides:

- Economically efficient goods throughput/transport over longer distances,

- Excellent operator comfort and ergonomics through cushioned stand-on platform,
- Safe traction also on uneven floors through "ProTrac",
- Easy handling/control through electric steering (optional).

No matter in what application the truck is just being used: Batteries up to a capacity of 375 Ah and the possibility to remove the battery from the side for multi-shift operation (optional) ensure that the truck is operational long enough even in the hardest applications.

ERC 212/214/216

ERC 212

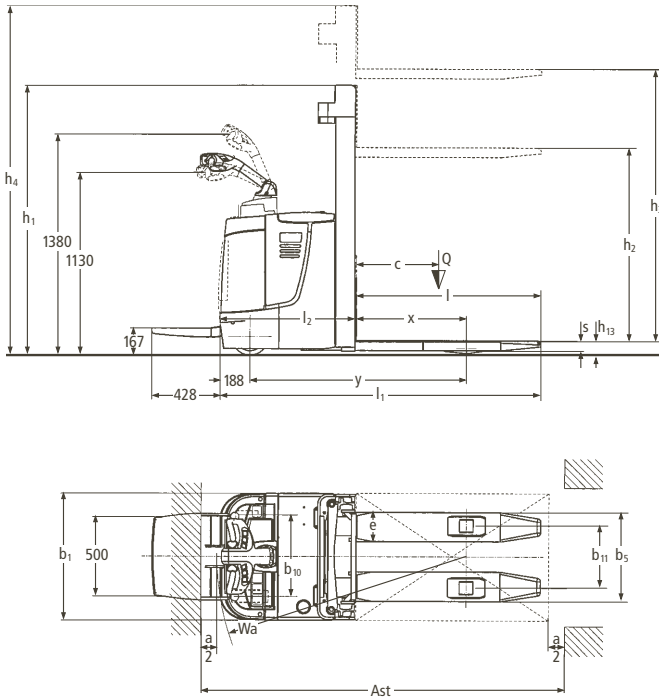

ERC 214/216

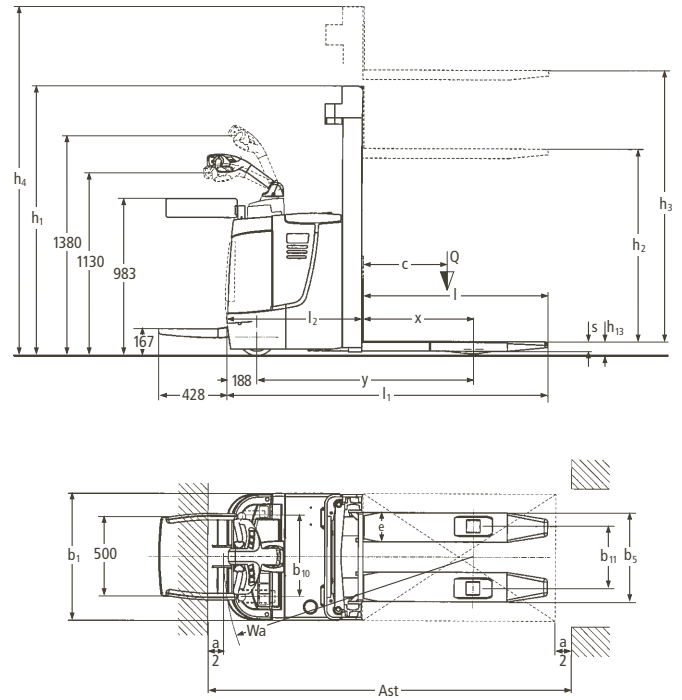

Standard mast types (mm)								
Mast types	Closed mast height	Lift height	Free lift	Extended mast height	Closed mast height	Lift height	Free lift	Extended mast height
	h_1	h_3	h_2	h_4	h_1	h_3	h_2	h_4
ERC 212/214				ERC 216				
Two-stage ZT	1750 ¹⁾	2500	100	2980	1750 ¹⁾	2400	100	2930
	1850 ¹⁾	2700	100	3180	1850 ¹⁾	2600	100	3130
	1950 ¹⁾	2900	100	3380	1950 ¹⁾	2800	100	3330
	2100 ¹⁾	3200	100	3680	2100 ¹⁾	3100	100	3630
	2300 ¹⁾	3600	100	4080	2300 ¹⁾	3500	100	4030
	—	—	—	—	2450 ¹⁾	3800	100	4330
	2550 ¹⁾	4100	100	4580	2550 ¹⁾	4000	100	4530
2650 ¹⁾	4300	100	4780	2650 ¹⁾	4200	100	4730	
Two-stage ZZ	1700	2500	1220	2980	1700	2400	1170	2930
	1900	2900	1420	3380	1900	2800	1370	3330
	2050	3200	1570	3680	2050	3100	1520	3630
	2250	3600	1770	4080	2250	3500	1720	4030
	2500	4100	2020	4580	2500	4000	1970	4530
	2600	4300	2120	4780	2600	4200	2070	4730
Three-stage DZ	1830	4090	1350	4570	1830	3990	1300	4520
	1900	4300	1420	4780	1900	4200	1370	4730
	2030 ²⁾	4690	1550	5180	2030	4590	1500	5130
	2250 ²⁾	5350	1770	5830	2250	5250	1720	5780

1) Closed mast height h_1 stated for 100 mm free lift
 2) Only ERC 214

Technical Data in line with VDI 2198 as at: 05/2007

Identification	1.1	Manufacturer (abbreviation)	Jungheinrich	Jungheinrich	Jungheinrich	1.1
	1.2	Manufacturer's type designation	ERC 212	ERC 214	ERC 216	1.2
	1.3	Drive: electric (battery or mains), diesel, petrol, fuel gas, manual	electric	electric	electric	1.3
	1.4	Type of operation: hand, pedestrian, standing, seated, order picker	pedestrian	pedestrian	pedestrian	1.4
	1.5	Load capacity/rated load Q (t)	1.2	1.4	1.6	1.5
	1.6	Load centre distance c (mm)	600	600	600	1.6
	1.8	Load distance, centre of drive axle to fork x (mm)	689 ¹⁾	689 ¹⁾	689 ¹⁾	1.8
	1.9	Wheelbase y (mm)	1357	1357	1357	1.9
	Weights	2.1	Service weight incl. battery (see line 6.5) kg	1220	1230	1230
2.2		Axle loading, laden front/rear kg	930/1490	940/1690	950/1880	2.2
2.3		Axle loading, unladen front/rear kg	880/340	890/340	890/340	2.3
Wheels, Chassis	3.1	Tyres: solid rubber, superelastic, pneumatic, polyurethane	Vulkollan®	Vulkollan®	Vulkollan®	3.1
	3.2	Tyre size, front	230 x 70	230 x 70	230 x 70	3.2
	3.3	Tyre size, rear	85 x 110 ³⁾	85 x 110 ³⁾	85 x 110 ³⁾	3.3
	3.4	Additional wheels (dimensions)	140 x 54	140 x 54	140 x 54	3.4
	3.5	Wheels, number front/rear (x = driven wheels)	1x + 1/2	1x + 1/2	1x + 1/2	3.5
	3.6	Track width, front b ₁₀ (mm)	513	513	513	3.6
	3.7	Track width, rear b ₁₁ (mm)	390	390	390	3.7
Basic Dimensions	4.2	Lowered mast height h ₁ (mm)	1750	1750	1750	4.2
	4.3	Free lift h ₂ (mm)	100	100	100	4.3
	4.4	Lift height h ₃ (mm)	2500	2500	2400	4.4
	4.5	Extended mast height h ₄ (mm)	2981	2981	2931	4.5
	4.9	Height of tiller in drive position min./max. h ₁₄ (mm)	1130/1380	1130/1380	1130/1380	4.9
	4.15	Lowered height h ₁₃ (mm)	90	90	90	4.15
	4.19	Overall length l ₁ (mm)	2006 ²⁾	2006 ²⁾	2006 ²⁾	4.19
	4.20	Length to face of forks l ₂ (mm)	856 ²⁾	856 ²⁾	856 ²⁾	4.20
	4.21	Overall width b ₁ /b ₂ (mm)	800	800	800	4.21
	4.22	Fork dimensions s/e/l (mm)	56 x 185 x 1150	56 x 185 x 1150	61 x 185 x 1150	4.22
	4.25	Width over forks b ₅ (mm)	570	570	570	4.25
	4.32	Ground clearance, centre of wheelbase m ₂ (mm)	30	30	30	4.32
	4.33	Aisle width for pallets 1000x1200 crossways Ast (mm)	2441 ²⁾	2441 ²⁾	2441 ²⁾	4.33
	4.34	Aisle width for pallets 800x1200 lengthways Ast (mm)	2414 ²⁾	2414 ²⁾	2414 ²⁾	4.34
	4.35	Turning radius Wa (mm)	1565	1565	1565	4.35
Performance Data	5.1	Travel speed, laden/unladen km/h	6.0/6.0	7.5/8.5	7.0/8.5	5.1
	5.2	Lift speed, laden/unladen m/s	0.19/0.26	0.18/0.26	0.17/0.26	5.2
	5.3	Lowering speed, laden/unladen m/s	0.43/0.43	0.43/0.43	0.43/0.43	5.3
	5.8	Max. gradient performance, laden/unladen %	9/16	8/16	7/16	5.8
	5.10	Service brake	electromagnetic	electromagnetic	electromagnetic	5.10
	E-Motor	6.1	Drive motor rating S ₂ 60 min. kW	2	2	2
6.2		Lift motor rating at S ₃ 15 % ⁴⁾ kW	3	3	3	6.2
6.3		Battery acc. to DIN 43531/35/36 A, B, C, no	B 3EPzS	B 3EPzS	B 3EPzS	6.3
6.4		Battery voltage, nominal capacity K ₅ V/Ah	24/345/330	24/345	24/345	6.4
6.5		Battery weight kg	288	288	288	6.5
6.6		Energy consumption acc. to VDI cycle kWh/h	1.52	1.66	1.83	6.6
Others	8.1	Type of drive control	impulse	impulse	impulse	8.1
	8.4	Sound level at driver's ear acc. to EN 12 053 dB(A)	68	68	68	8.4
1) DZ - 35 mm; ERC 216 = DZ - 43 mm 2) DZ +35 mm; ERC 216 = DZ +43 mm 3) Tandem: 85 x 85 4) at S ₃ 10 %						

This specification sheet according to VDI regulation 2198 only provides technical values for the standard truck. Non-standard tyres, different masts, additional equipment, etc. could produce other values. Right reserved for technical changes and improvements.

Make use of the advantages



ERC 212 with stand-on platform folded up/down

Flexible application opportunities

Various platform types provide different utilisation opportunities:

Type 1: foldable stand-on platform without side supports (ERC 212)

- Pedestrian operation.
- Maximum travel speed (6 km/h) with folded down stand-on platform.
- Reduced travel speed (4.4 km/h) with stand-on platform folded up.

Type 2: foldable stand-on platform with side supports (ERC 214/216)

- Pedestrian/stand-on operation.
- Reduced travel speed (6 km/h) with folded in side supports.
- Reduced travel speed (4.4 km/h) in pedestrian operation.

Powerful drive motor and "intelligent" controls

Advanced drive technology with powerful 2 kW shunt-wound drive motor (KB 60 min) and control electronics (SpeedControl) ensure safe travel characteristics. Adjustable to every application:

- The determined travel speed is maintained in every travel situation – even on ascending/descending gradients.

- Individually adjustable travel parameters facilitate optimum adjustment to every requirement.
- Energy reclamation through regenerative braking on taking back the travel speed.
- 2-year warranty on drive motor.

Comfortable stacking and retrieval

All lifting and lowering functions are comfortably controlled from the tiller head without the need to turn round. Here the Jungheinrich Proportional Hydraulics facilitate sensitive control of lifting and lowering speed – essential for precise and gentle depositing of loads in the racking or exact positioning of the load for stacking in. In confined spaces, stand-on platform and side guards are simply folded in and the ERC is used in pedestrian mode. The low height of the platform ensures easy mounting/dismounting.



Retrieval with the ERC

Optimum traction at any time

Jungheinrich-ProTrac optimises traction on the drive wheel. A spring cushioned system in the support wheel prevents the drive wheel from skidding on uneven floors. ProTrac provides stability on all four wheels during stacking and retrieval through hydraulic locking of the support wheel from 1800 mm lift height.



Buttons for sensitive lifting and lowering as well as horn

Comfortable and safe operation

- The electric tiller steering (optional) reduces tiller movement during straight travel. The advantage: directional stability during straight travel. Also, low steering forces ensure fatigue-free operation.
- The buttons on the tiller for sensitive lifting and lowering have different shapes. The operator "feels" the button he has pressed and thus always "keeps his eyes" on the load during stacking and retrieval.
- The sprung stand-on platform absorbs even severe track unevenness and thus relieves any strain on the operator's back.

Long operating times

Battery capacities up to 375 Ah ensure long operating times:

- 3 EPzS 240 / 3 EPzS 270/345 (375) Ah.
- Sideways battery removal, e.g. for multi-shift operation (optional).

Additional equipment

- "CanDis" and access entitlement "CanCode".
- Cold store version.
- Vertical load guard.

Jungheinrich UK Ltd.

Head Office:

Sherbourne House · Sherbourne Drive
Tilbrook · Milton Keynes MK7 8HX
Phone 01908 363100
Fax 01908 363180

info@jungheinrich.co.uk
www.jungheinrich.co.uk

Jungheinrich AG
ISO 9001, ISO 14001
Certification of Quality and
Environment Management.



Jungheinrich trucks
conform to the European
Safety Requirements.



JUNGHEINRICH
Well worthwhile