

**Stand-on platform
for flexible operation**

**High ground clearance
through support arm lift**

**Electric tiller steering
for effortless steering**

**Sensitive lifting/lowering
through Proportional Hydraulics**

**Safe travel through
SpeedControl**



ERC Z12/Z14/Z16

Electric pedestrian operated stacker with support arm lift (1200/1400/1600 kg)

The Jungheinrich ERC Z12/Z14/Z16 is a combination of manoeuvrable pedestrian stacker and fast, comfortable stand-on truck.

As a pedestrian stacker, the ERC Z provides:

- Excellent visibility through the slender mast.
- Comfortable operation of lifting/lowering function from the tiller head.
- Depositing in racking locations up to 5350 mm (ERC Z14).
- Safe 4-point wheel traction during stacking and retrieval through hydraulic locking of the support wheels.
- Sensitive lifting and lowering speed control through Jungheinrich Proportional Hydraulics – e.g. for precise and gentle depositing of the load in the racking.

The special feature of the support arm lift: the effortless operation on uneven floors, ramps, transfer plates, loading ramps through 142 mm floor clearance – even fully laden. Support arm and mast lift operate independently from each other. This facilitates the doubledeck transport of two pallets at the same time.

Other advantages:

- Automatic lowering of support arms from 1800 mm lift height for maximum stability.
- ProTrac providing safe traction even on uneven floors.
- Easy handling/control through electric steering.

- Superb comfort and easy on the operator's back through sprung stand-on platform. The low height of the stand-on platform provides easy and fast mounting or dismounting.

And if space becomes tight during stacking or, for example, during load pick-up in lorries, the operator stand-on platform and side guards are simply folded away and the ERC Z is transformed back into a space-saving pedestrian truck.

No matter in what application the truck is just being used: Batteries up to a capacity of 375 Ah ensure that the ERC Z is operational long enough even in the hardest applications.

**JUNGHEINRICH**

ERC Z12/Z14/Z16

ERC Z12

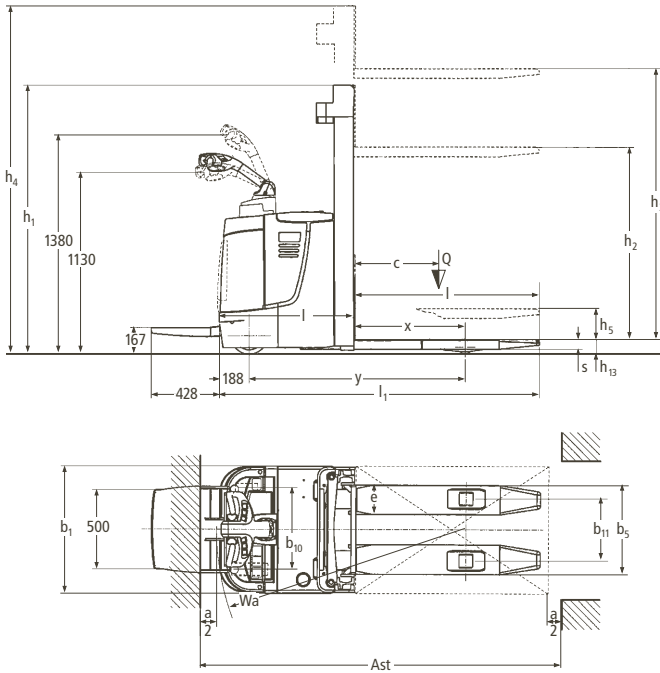

ERC Z14/Z16

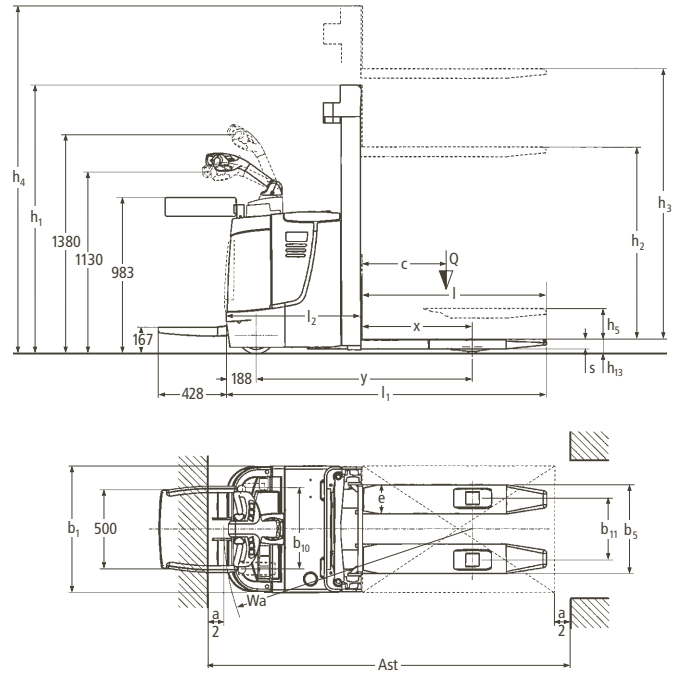

Standard mast types (mm)								
Mast types	Closed mast height	Lift height	Free lift	Extended mast height	Closed mast height	Lift height	Free lift	Extended mast height
	h_1	h_3	h_2	h_4	h_1	h_3	h_2	h_4
	ERC Z12/Z14				ERC Z16			
Two-stage ZT	1750 ¹⁾	2500	100	2980	1750 ¹⁾	2400	100	2930
	1850 ¹⁾	2700	100	3180	1850 ¹⁾	2600	100	3130
	1950 ¹⁾	2900	100	3380	1950 ¹⁾	2800	100	3330
	2100 ¹⁾	3200	100	3680	2100 ¹⁾	3100	100	3630
	2300 ¹⁾	3600	100	4080	2300 ¹⁾	3500	100	4030
	—	—	—	—	2450 ¹⁾	3800	100	4330
	2550 ¹⁾	4100	100	4580	2550 ¹⁾	4000	100	4530
					2650 ¹⁾	4200	100	4730
Two-stage ZZ	1700	2500	1220	2980	1700	2400	1170	2930
	1900	2900	1420	3380	1900	2800	1370	3330
	2050	3200	1570	3680	2050	3100	1520	3630
	2250	3600	1770	4080	2250	3500	1720	4030
	2500	4100	2020	4580	2500	4000	1970	4530
	2600	4300	2120	4780	2600	4200	2070	4730
Three-stage DZ	1830	4090	1350	4570	1830	3990	1300	4520
	1900	4300	1420	4780	1900	4200	1370	4730
	2030 ²⁾	4690	1550	5180	2030	4590	1500	5130
	2250 ²⁾	5350	1770	5830	2250	5250	1720	5780

1) Closed mast height h_1 stated for 100 mm free lift

2) Only ERC Z14

Technical Data in line with VDI 2198 as at: 01/2007

Identification	1.1	Manufacturer (abbreviation)		Jungheinrich	Jungheinrich	Jungheinrich	1.1
	1.2	Manufacturer's type designation		ERC Z12	ERC Z14	ERC Z16	1.2
	1.3	Drive: electric (battery or mains), diesel, petrol, fuel gas, manual		electric	electric	electric	1.3
	1.4	Type of operation: hand, pedestrian, standing, seated, order picker		pedestrian	pedestrian	pedestrian	1.4
	1.5	Load capacity/rated load	Q (t)	1.2	1.4	1.6	1.5
	1.6	Load centre distance	c (mm)	600	600	600	1.6
	1.8	Load distance, centre of drive axle to fork	x (mm)	899 ¹⁾²⁾	899 ¹⁾²⁾	899 ¹⁾²⁾	1.8
	1.9	Wheelbase	y (mm)	1599 ¹⁾	1599 ¹⁾	1599 ¹⁾	1.9
	Weights	2.1	Service weight incl. battery (see line 6.5)	kg	1300	1310	1310
2.2		Axle loading, laden front/rear	kg	1190/1310	1230/1480	1270/1640	2.2
2.3		Axle loading, unladen front/rear	kg	960/340	970/340	970/340	2.3
Wheels, Chassis	3.1	Tyres: solid rubber, superelastic, pneumatic, polyurethane		Vulkollan®	Vulkollan®	Vulkollan®	3.1
	3.2	Tyre size, front		230 x 70	230 x 70	230 x 70	3.2
	3.3	Tyre size, rear		85 x 95 ⁴⁾	85 x 95 ⁴⁾	85 x 95 ⁴⁾	3.3
	3.4	Additional wheels (dimensions)		140 x 54	140 x 54	140 x 54	3.4
	3.5	Wheels, number front/rear (x = driven wheels)		1x + 1/2	1x + 1/2	1x + 1/2	3.5
	3.6	Track width, front	b ₁₀ (mm)	513	513	513	3.6
	3.7	Track width, rear	b ₁₁ (mm)	375	375	375	3.7
Basic Dimensions	4.2	Lowered mast height	h ₁ (mm)	1750	1750	1750	4.2
	4.3	Free lift	h ₂ (mm)	100	100	100	4.3
	4.4	Lift height	h ₃ (mm)	2500	2500	2400	4.4
	4.5	Extended mast height	h ₄ (mm)	2981	2981	2931	4.5
	4.6	Initial lift	h ₅ (mm)	122	122	122	4.6
	4.9	Height of tiller in drive position min./max.	h ₁₄ (mm)	1130/1380	1130/1380	1130/1380	4.9
	4.15	Lowered height	h ₁₃ (mm)	90	90	90	4.15
	4.19	Overall length	l ₁ (mm)	2038 ³⁾	2038 ³⁾	2038 ³⁾	4.19
	4.20	Length to face of forks	l ₂ (mm)	888 ³⁾	888 ³⁾	888 ³⁾	4.20
	4.21	Overall width	b ₁ /b ₂ (mm)	836	836	836	4.21
	4.22	Fork dimensions	s/e/l (mm)	56 x 185 x 1150	56 x 185 x 1150	61 x 185 x 1150	4.22
	4.25	Width over forks	b ₅ (mm)	570	570	570	4.25
	4.32	Ground clearance, centre of wheelbase	m ₂ (mm)	20	20	20	4.32
	4.33	Aisle width for pallets 1000 x 1200 crossways	Ast (mm)	2565 ³⁾	2565 ³⁾	2565 ³⁾	4.33
	4.34	Aisle width for pallets 800 x 1200 lengthways	Ast (mm)	2483 ³⁾	2483 ³⁾	2483 ³⁾	4.34
4.35	Turning radius	Wa (mm)	1804/1744	1804/1744	1804/1744	4.35	
Performance Data	5.1	Travel speed, laden/unladen	km/h	6.0/6.0	7.5/8.5	7.0/8.5	5.1
	5.2	Lift speed, laden/unladen	m/s	0.19/0.26	0.18/0.26	0.17/0.26	5.2
	5.3	Lowering speed, laden/unladen	m/s	0.43/0.43	0.43/0.43	0.43/0.43	5.3
	5.8	Max. gradient performance, laden/unladen	%	9/16	8/16	7/16	5.8
	5.10	Service brake		electromagnetic	electromagnetic	electromagnetic	5.10
	E-Motor	6.1	Drive motor rating S ₂ 60 min.	kW	2	2	2
6.2		Lift motor rating at S ₃ 15 % ⁵⁾	kW	3	3	3	6.2
6.3		Battery acc. to DIN 43531/35/36 A, B, C, no		B 3 EPzS	B 3 EPzS	B 3 EPzS	6.3
6.4		Battery voltage, nominal capacity K ₅	V/Ah	24/345	24/345	24/345	6.4
6.6		Energy consumption acc. to VDI cycle	kWh/h	1.52	1.66	1.83	6.6
Others	8.1	Type of drive control		Impulse	Impulse	Impulse	8.1
	8.4	Sound level at driver's ear acc. to EN 12 053	dB(A)	68	68	68	8.4

- 1) Load section raised – 60 mm
2) DZ – 35 mm, ERC Z16 = DZ – 43 mm
3) DZ + 35 mm, ERC Z16 = DZ + 43 mm
4) Tandem 85 x 85
5) At S₃ 10 %

Make use of the advantages



ERC Z14 with lowered forks ①, with raised support arm lift ② and with raised mast lift ③

Versatile application possibilities

- 122 mm additional support arm lift for safe "negotiation" of obstacles, dock levels or floor undulations.
- Transport of enclosed pallets.
- Easy pick-up of quarter/half pallets on Euro pallets.
- Transporting two pallets at the same time and thus doubling throughput.

Powerful drive motor and "intelligent" controls

Advanced drive technology and control electronics (SpeedControl) ensure safe travel characteristics with adjustment opportunities for every application:

- The determined travel speed is maintained in every travel situation – even on ascending/descending gradients.
- Energy reclamation through regenerative braking.
- 2-year warranty on drive motor.

Optimum traction at any time

Jungheinrich ProTrac optimises traction on the drive wheel. A spring cushioned system in the support wheel prevents the drive wheel from skidding on uneven floors. ProTrac pro-

vides stability on all four wheels during stacking and retrieval through hydraulic locking of the support wheel from 1800 mm lift height.

Comfortable and safe operation

- The electric tiller steering (optional) reduces tiller movement during straight travel to ensure directional stability. Also, low steering forces ensure fatigue-free operation.
- The buttons on the tiller for sensitive lifting and lowering have different shapes. The operator "feels" the button he has pressed and thus always "keeps his eyes" on the load during stacking and retrieval.
- The sprung stand-on platform absorbs even severe track unevenness and thus relieves any strain on the operator's back.

Comfortable stacking and retrieval

All lifting and lowering functions are comfortably controlled from the tiller head without the need to turn round. Here the



Buttons for sensitive lifting and lowering as well as horn

Jungheinrich Proportional Hydraulics facilitate sensitive control of lifting and lowering speed – essential for precise and gentle depositing of loads in the racking or exact positioning of the load for stacking in.



Access entitlement through CanCode and CanDis

Well informed at any time

Extensive control instruments give the operator the feeling of having a complete overview at any time.

- Information display CanDis (optional) with additional operating hour display and service code memory.
- Truck access entitlement through CanCode (optional).
- Further truck parameter adjustment opportunities (optional).

Long operating times

Battery capacities up to 375 Ah ensure long operating times:

- 3 EPzS 240/3 EPzS 270/345 (375) Ah.

Additional equipment

- Cold store version.
- Vertical load guard.

Jungheinrich UK Ltd.

Head Office:

Sherbourne House · Sherbourne Drive
Tilbrook · Milton Keynes MK7 8HX
Phone 01908 363100
Fax 01908 363180

info@jungheinrich.co.uk
www.jungheinrich.co.uk

Jungheinrich AG
ISO 9001, ISO 14001
Certification of Quality and
Environment Management.



Jungheinrich trucks
conform to the European
Safety Requirements.



JUNGHEINRICH
Well worthwhile