

**High performance
drive motor for high speed
and powerful acceleration**

Compact design

**ProTracLink for optimum
travel characteristics**

Electric tiller steering

**Ideal for lorry loading
and unloading**



ERE K20

Electric stand-on pallet truck (2000 kg)

The ERE K20 is a horizontal mover for utilisation in narrow aisles and for lorry loading and unloading. With a total width of only 720 mm, the truck can be manoeuvred quickly and safely even in the most confined spaces.

Effective operator platform damping reduces vibration for the driver and the padded side panels provide safe support

in every travel direction and protect the operator within the confines of the truck.

Driver comfort is improved by electric steering and a short tiller with a multi-functional head for comfortable, effortless and safe operation.

The high capacity 2.5 kW drive motor ensures powerful acceleration and high

top speeds for rapid goods throughput. The ERE K20 is available with battery capacities up to 500 Ah for long operating times without battery change.

ERE K20

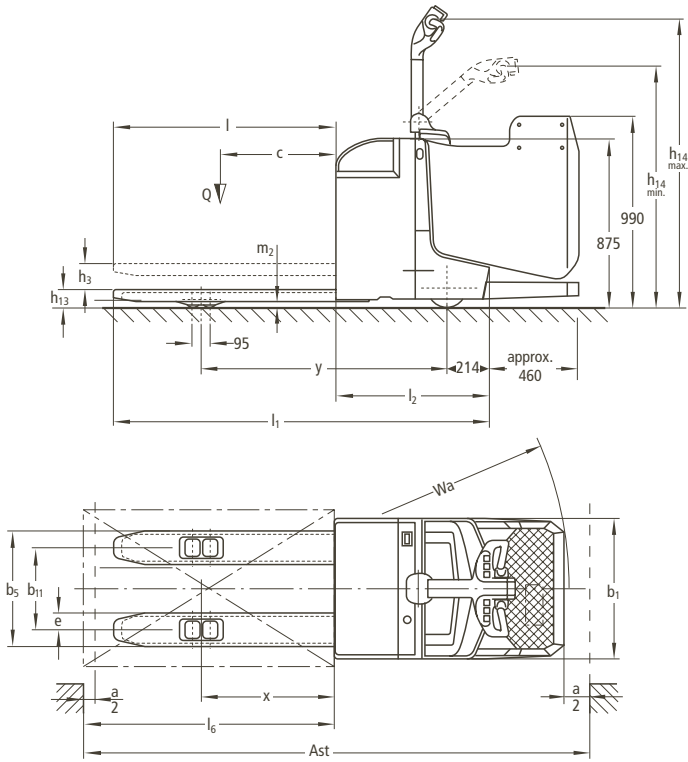

Technical Data in line with VDI 2198 as at: 10/2006

Identification	1.1	Manufacturer (abbreviation)		Jungheinrich	Jungheinrich	1.1
	1.2	Manufacturer's type designation		ERE K20	ERE K20 XL	1.2
	1.3	Drive (electric – battery or mains, diesel, petrol, fuel gas, manual)		electric	electric	1.3
	1.4	Type of operation (hand, pedestrian, standing, seated, order picker)		standing	standing	1.4
	1.5	Load capacity at support arm lift	Q (t)	2	2	1.5
	1.8	Load distance, centre of drive axle to fork	x (mm)	1756 ¹⁾	1756 ¹⁾	1.8
	1.9	Wheelbase	y (mm)	2340 ¹⁾	2405 ¹⁾	1.9
	2.1	Service weight incl. battery (see line 6.5)	kg	922	996	2.1
Weights	2.2	Axle loading, laden front/rear	kg	1233/1689	1292/1704	2.2
	2.3	Axle loading, unladen front/rear	kg	766/156	825/171	2.3
	3.1	Tyres (solid rubber, superelastic, pneumatic, polyurethane)		Vulkollan®	Vulkollan®	3.1
	3.2	Tyre size, front		230 x 77	230 x 77	3.2
	3.3	Tyre size, rear		85 x 85	85 x 85	3.3
	3.4	Additional wheels (dimensions)		125 x 54	125 x 54	3.4
	3.5	Wheels, number front/rear (x = driven wheels)		3-1x/4	3-1x/4	3.5
	3.6	Track width, front	b ₁₀ (mm)	500	500	3.6
Wheels, Chassis	3.7	Track width, rear	b ₁₁ (mm)	380	380	3.7
	4.4	Lift height	h ₃ (mm)	125	125	4.4
	4.9	Height of tiller in drive position min./max.	h ₁₄ (mm)	1170/1400	1170/1400	4.9
	4.15	Lowered height	h ₁₃ (mm)	85	85	4.15
	4.19	Overall length	l ₁ (mm)	3660	3725	4.19
	4.20	Length to face of forks	l ₂ (mm)	723	788	4.20
	4.21	Overall width	b ₁ /b ₂ (mm)	720/–	720/–	4.21
	4.22	Fork dimensions	s/e/l (mm)	55 x 170 x 2400	55 x 170 x 2400	4.22
	4.25	Width over forks	b ₅ (mm)	540	540	4.25
	4.32	Ground clearance, centre of wheelbase	m ₂ (mm)	30	30	4.32
	4.34	Aisle width for pallets 800 x 1200 lengthways	Ast (mm)	3873 ²⁾	3938 ²⁾	4.34
	4.35	Turning radius	Wa (mm)	2988 ¹⁾	3053 ¹⁾	4.35
	5.1	Travel speed, laden/unladen	km/h	9.5/11.5	9.5/11.5	5.1
	5.2	Lift speed, laden/unladen	m/s	0.04/0.056	0.04/0.056	5.2
	5.3	Lowering speed, laden/unladen	m/s	0.056/0.05	0.056/0.05	5.3
	5.7	Gradient performance, laden/unladen	%	8/15	8/15	5.7
Performance Data	5.8	Max. gradient performance, laden/unladen	%	8/15	8/15	5.8
	5.10	Service brake		electromechanic	electromechanic	5.10
	6.1	Drive motor rating S ₂ 60 min.	kW	2.5	2.5	6.1
	6.2	Lift motor rating at S ₃ 15 %	kW	2	2	6.2
E-Motor	6.4	Battery voltage, nominal capacity K ₅	V/Ah	24/345 (375)	24/460 (500)	6.4
	6.5	Battery weight	kg	288	362	6.5
Others	8.1	Type of drive control		impulse	impulse	8.1

1) load section lowered +90 mm

2) Ast according to VDI diagonal method, lowered +165 mm

Make use of the advantages

High performance drive motor and "intelligent" controls

Advanced motor technology, Impulse control SpeedControl and individually adjustable travel parameters ensure safe operation in every application.

- The travel speed set on the travel switch is maintained in every travel situation – also on upward and downward gradients.
- The ERE is automatically braked during unintentional rolling on ramps.
- Energy reclamation through regenerative braking on reduction of travel speed.
- 2-year warranty on drive motor.

Flexible application opportunities and high travel comfort

- Comfortable ride-on operation through fixed stand-on platform.
- Low overall width of only 720 mm, suitable for utilisation in narrow aisles, ware-



Optimum operating position through short tiller

house areas or for loading and unloading lorries.

- Fixed side supports for safe support also on corners and for making optimum use of speed and manoeuvrability whenever operating in tight spaces.
- Electric tiller steering and multi-functional tiller head for safe and simple operation.

Long operating times

Battery capacities up to 500 Ah ensure long operating times.

- Long version: 3 PzS 345/375 Ah.
- Extra long version: 4 PzS 460/500 Ah.

Optimum cornering ability

Sprung, hydraulically cushioned support wheels – connected via "ProTraLink" – distribute the lateral forces dependent on the operating situation: evenly over all wheels for straight travel and concentrated on the outer support wheel on corners.

Well-informed at any time

Extensive control instruments give the operator the good feeling of having everything under control at any time:

- Information display "CanDis" (optional) with additional operating hour display and service code memory.
- Activation of truck via PIN through "CanCode" (optional).
- Further travel parameter adjustment options (optional).

Reduced maintenance work

Service-friendly components ensure long-term reduction in operating costs:

- Easy access to all components via a one-piece front cover fastened with only two screws.
- Low wear on support wheels through level adjustment when approaching a ramp at an angle: through a mechanical link, both support wheels are always at



Operator stand with fixed side panels

the same height. As opposed to a spring-loaded support wheel, they do not hit anything and thus are not damaged.

- The type of form-closed wheel rims – exclusive to Jungheinrich – ensure a long service life for load wheels, even in the hardest applications.



Specially suitable for travelling in narrow aisles

Jungheinrich UK Ltd.

Head Office:

Sherbourne House · Sherbourne Drive
Tilbrook · Milton Keynes MK7 8HX
Phone 01908 363100
Fax 01908 363180

info@jungheinrich.co.uk
www.jungheinrich.co.uk

Jungheinrich AG
ISO 9001, ISO 14001
Certification of Quality and
Environment Management.



Jungheinrich trucks
conform to the European
Safety Requirements.



JUNGHEINRICH
Well worthwhile